

Area of Base Parcel
3936m²

REFERENCE MARKS

STN	TO	ORIGIN	BEARING	DIST
1	O.Screw in Kb	26/SP258078	196°55'	6.804
1	O.Screw in Kb	26/SP258078	163°51'	22.13
1	O.Nail in Conc	1/SP300168	136°48'	2.742
2	O.Screw in Kb	21/SP258078	177°57'	5.566
4	O.Screw in Kb	23/SP258078	144°35'30"	12.67
5	O.Screw in Kb	7/SP290652	230°0'	6.337
6	O.Screw in Kb	8/SP290652	275°55'	7.228

PERMANENT MARKS

PM	ORIGIN	BEARING	DIST	NO	TYPE
3-OPM	30/SP290652	181°52'40"	15.186	189396	Bolt & washer

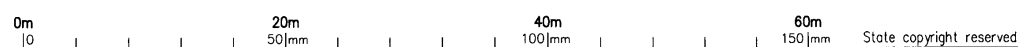

I, David Neil BAKER, hereby certify that the land comprised in this plan was surveyed by me personally and that the plan is accurate, that the said survey was performed in accordance with the Survey and Mapping Infrastructure Act 2003 and Surveyors Act 2003 and associated Regulations and Standards and that the said survey was completed on 20/03/2020.

24-3-2020
Date

Cadastral Surveyor

Plan of Lots 101-118, 201-219, 301-319, 401-419, 501-519, 601-610 & Common Property

Cancelling Lots 6 & 7 on SP290652

LOCAL GOVERNMENT: SUNSHINE COAST REGIONAL COUNCIL LOCALITY: SIPPY DOWNS

Meridian: SP290652

Survey Records: No

Scale: 1:400

Format: BUILDING



SP300172

State copyright reserved.

**WARNING : Folded or Mutilated Plans will not be accepted.
Plans may be rolled.
Information may not be placed in the outer margins.**

720030840

\$10887.00
29/04/2020 08:58

BE 400 NT

5. Lodged by

Shand Taylor Lawyers

BE 196A

(Include address, phone number, reference, and Lodger Code)

1. Certificate of Registered Owners or Lessees.

I/We **HABITAT DEVELOPMENT GROUP PTY LTD A.C.N. 002 615 741**
TRUSTEE UNDER INSTRUMENT 711395706

(Names in full)

* as Registered Owners of this land agree to this plan and dedicate the Public Use Land as shown hereon in accordance with Section 50 of the Land Title Act 1994.

* as Lessees of this land agree to this plan.

Signature of * Registered Owners * Lessees

[Signature] Director
[Signature] Director

* Rule out whichever is inapplicable

2. Planning Body Approval.

* *Sunshine Coast Regional Council*
hereby approves this plan in accordance with the :
% *Planning Act 2016*

Dated this *24th* day of *April 2020*

[Signature]
DELEGATED OFFICER
RICHARD MACGILLIVRAY
COORDINATOR - ENGINEERING & ENVIRONMENT
ASSESSMENT UNIT
SUNSHINE COAST REGIONAL COUNCIL

* Insert the name of the Planning Body.
Insert designation of signatory or delegation

3. Plans with Community Management Statement :

CMS Number : *53603*
Name : 'FOREST EDGE AND BOTANICA' CTS

4. References :

Dept File :
Local Govt : *Pos20-0073*
Surveyor : *190202*

6. Existing		Created		
Title Reference	Description	New Lots	Road	Secondary Interests
51153368	Lot 6 on SP290652	101-110, 201-210, 301-310, 401-410, 501-510, 601-610 & CP		
51153369	Lot 7 on SP290652	111-118, 211-219, 311-319, 411-419, 511-519 & CP		

MORTGAGE ALLOCATIONS

Mortgage	Lots Fully Encumbered	Lots Partially Encumbered
715373421	101-118, 201-219, 301-319, 401-419, 501-519 & 601-610	

ENCUMBRANCE EASEMENT ALLOCATIONS

Easement	Lots to be Encumbered
718862485 (Emt.K on SP290652)	102 & CP
718862485 (Emt.N on SP290652)	219 & CP
719968239 (Emt.A on SP300168)	CP

Reinstatement Report

All measurements in agreement with SP290652.

Development Approval : 14th January 2019

9. Building Format Plans only.

I certify that :
* As far as it is practical to determine, no part of the building shown on this plan encroaches onto adjoining lots or road;
~~* Part of the building shown on this plan encroaches onto adjoining lots and road~~

[Signature] 24-3-20
Cadastral Surveyor/Director * Date
~~* delete words not required~~

101-118, 201-219,
301-319, 401-419,
501-519, 601-610
& CP
Por.351

Lots	Orig

7. Orig Grant Allocation :

8. Passed & Endorsed :

By : *DNRME*
Date : *27-04-2020*
Signed : *DAVID BAKER FOR STEVE MCLOSNER*
Designation : *CADASTRAL SURVEYOR*

10. Lodgement Fees :

Survey Deposit	\$
Lodgement	\$
New Titles	\$
Photocopy	\$
Postage	\$
TOTAL	\$

11. Insert Plan Number

SP300172

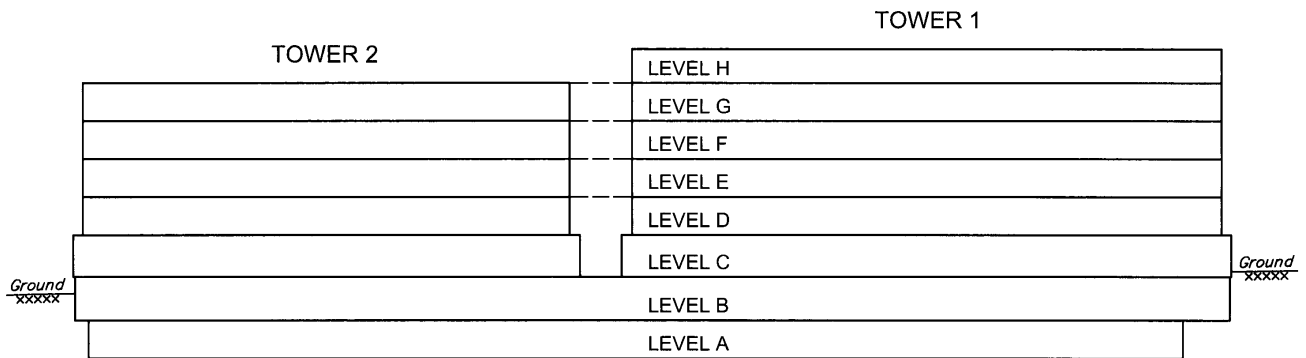

LATERAL ASPECT
(Viewed from the South West)
Scale 1:400

Scale 1: 400 – Lengths are in Metres.

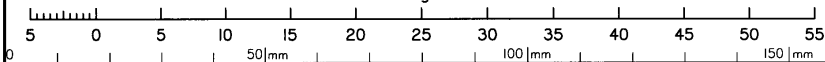

State copyright reserved.

Insert
Plan
Number

SP300172

LEVEL A

Scale 1:300

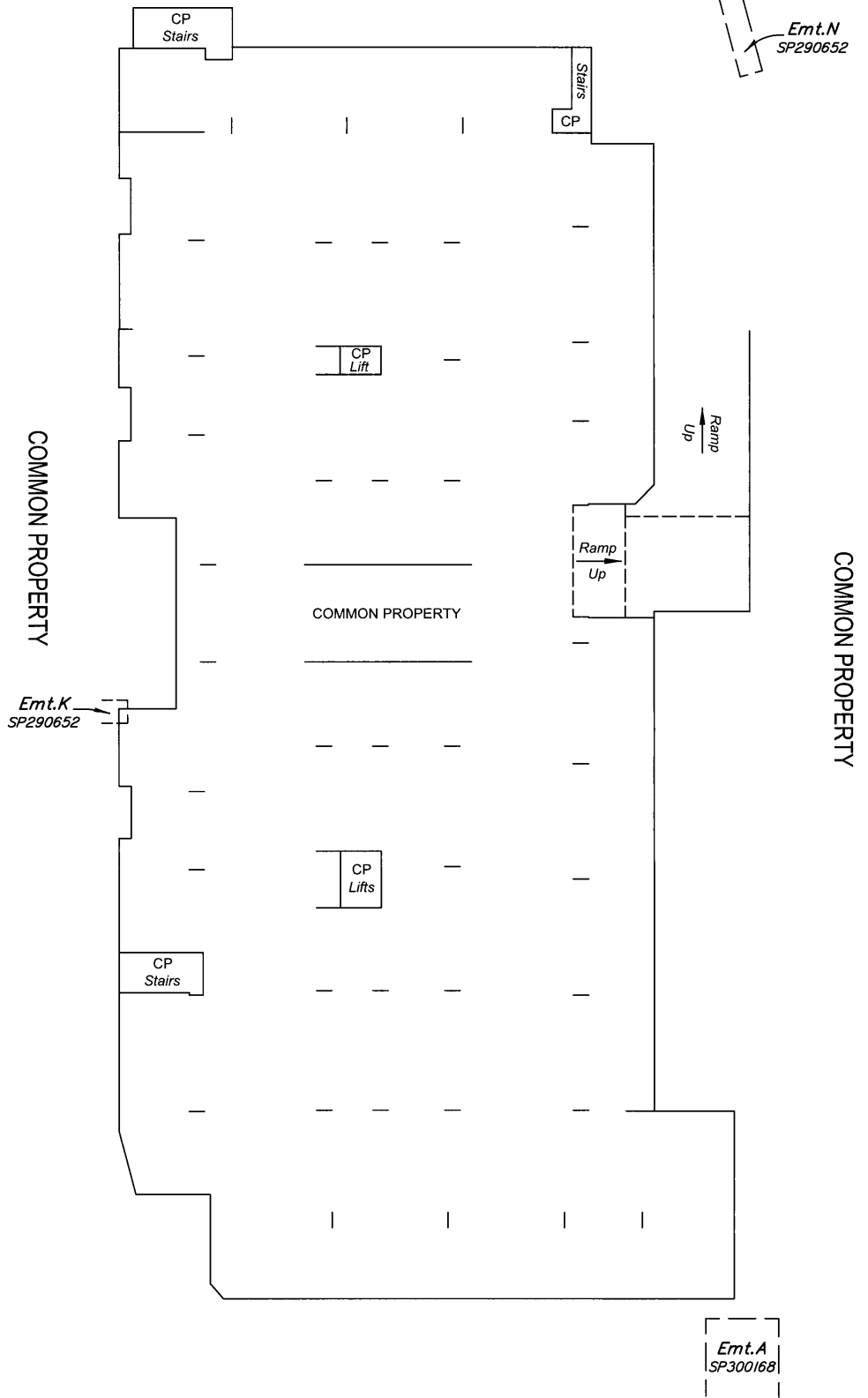
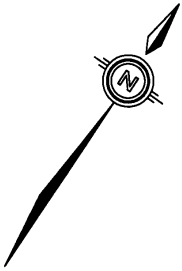

Scale 1:300 – Lengths are in Metres.

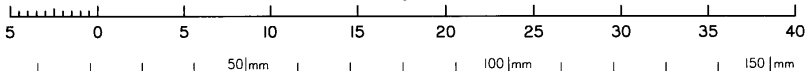

State copyright reserved.

Insert Plan Number **SP300172**

LEVEL B

Scale 1:300

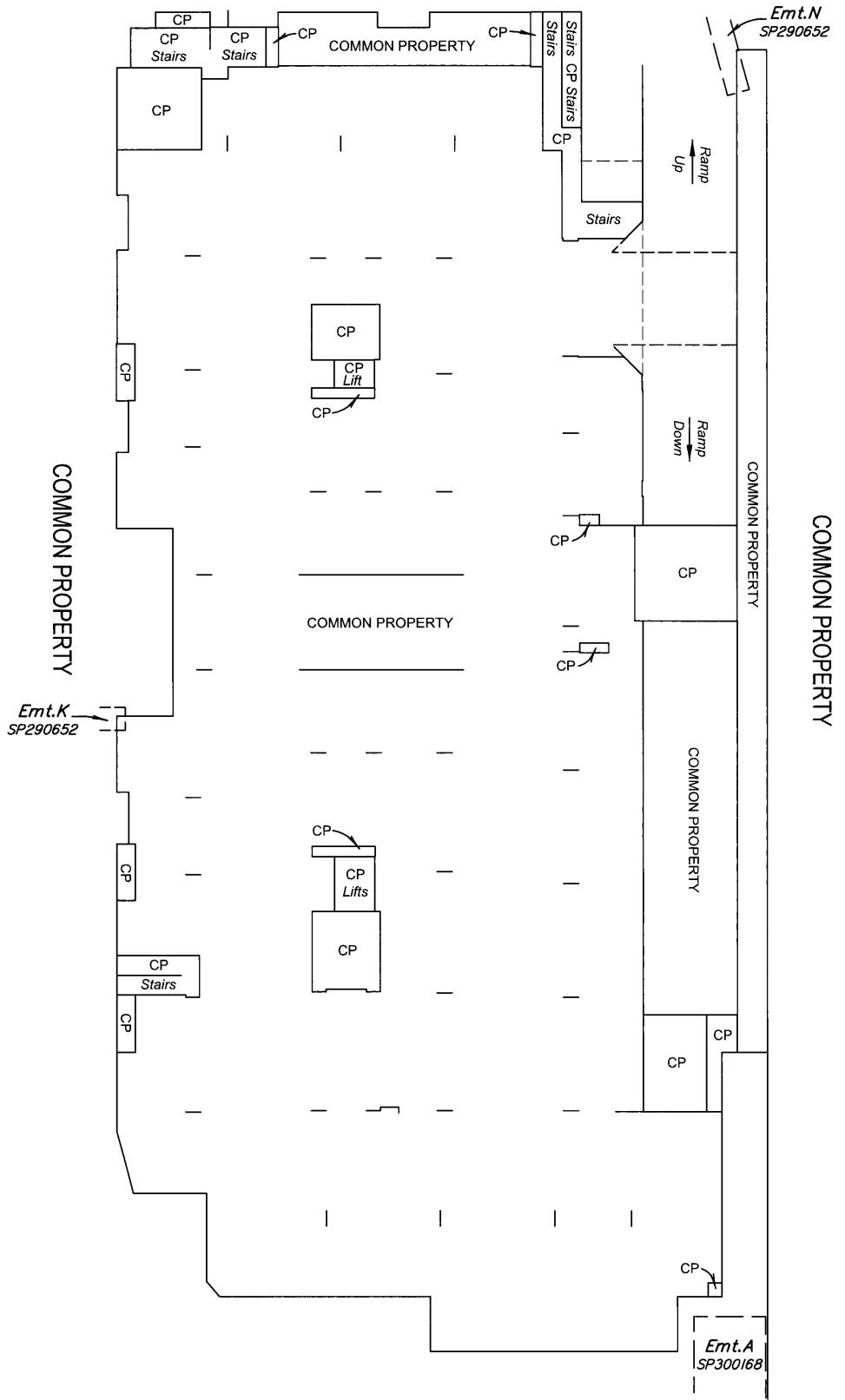
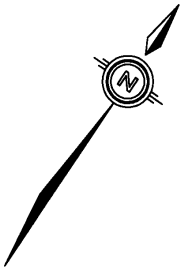

--- DENOTES LEVEL BELOW

Scale 1:300 - Lengths are in Metres.

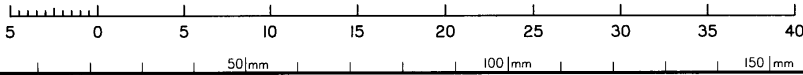

State copyright reserved.

Insert Plan Number **SP300172**

LEVEL C

Scale 1:300

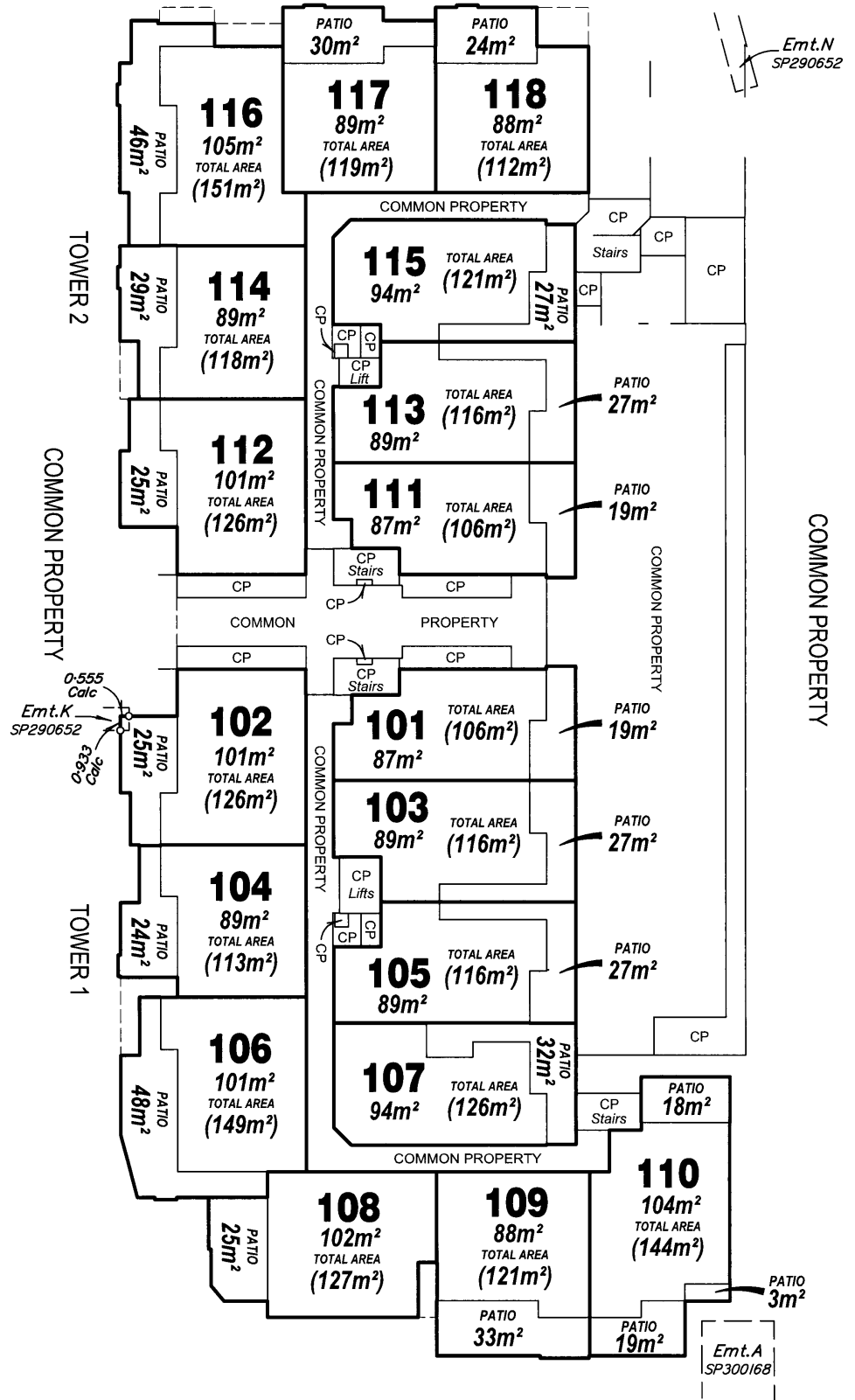
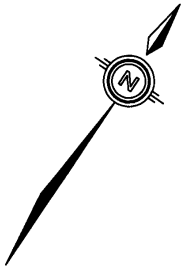

--- DENOTES LEVEL BELOW

Scale 1:300 – Lengths are in Metres.

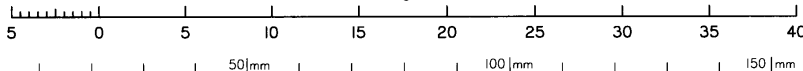

State copyright reserved.

Insert Plan Number **SP300172**

LEVEL D

Scale 1:300

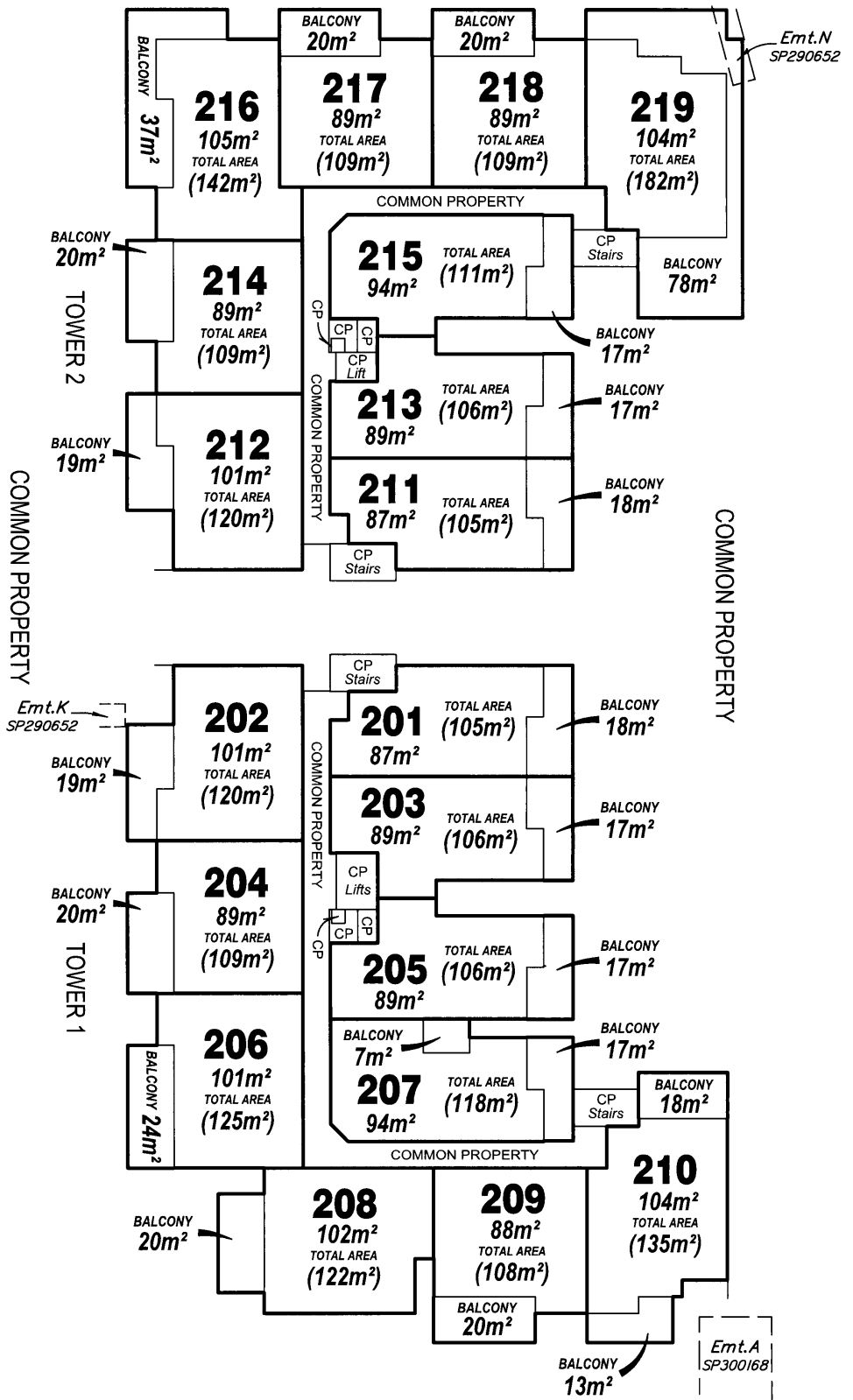
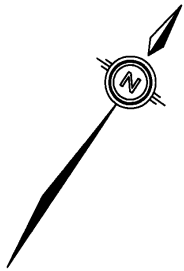

Scale 1:300 - Lengths are in Metres.

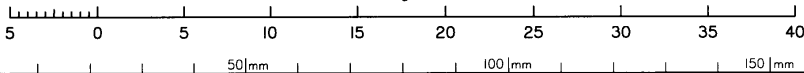

State copyright reserved.

Insert Plan Number **SP300172**

LEVEL E

Scale 1:300

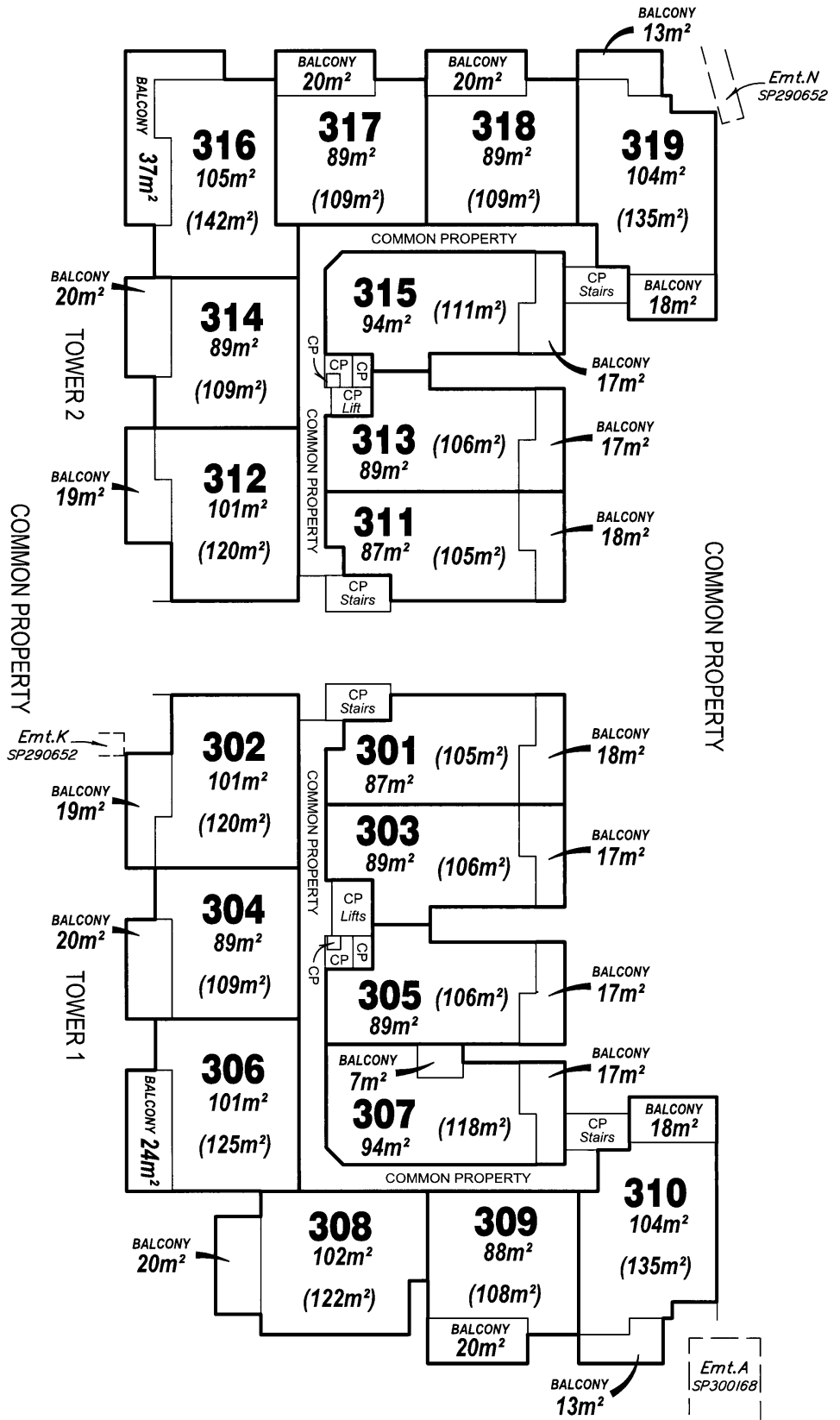
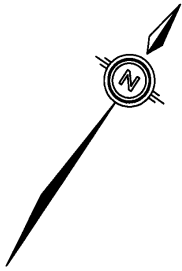

Scale 1:300 - Lengths are in Metres.

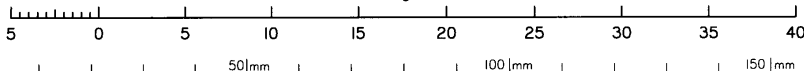

State copyright reserved.

Insert Plan Number **SP300172**

LEVEL F

Scale 1:300

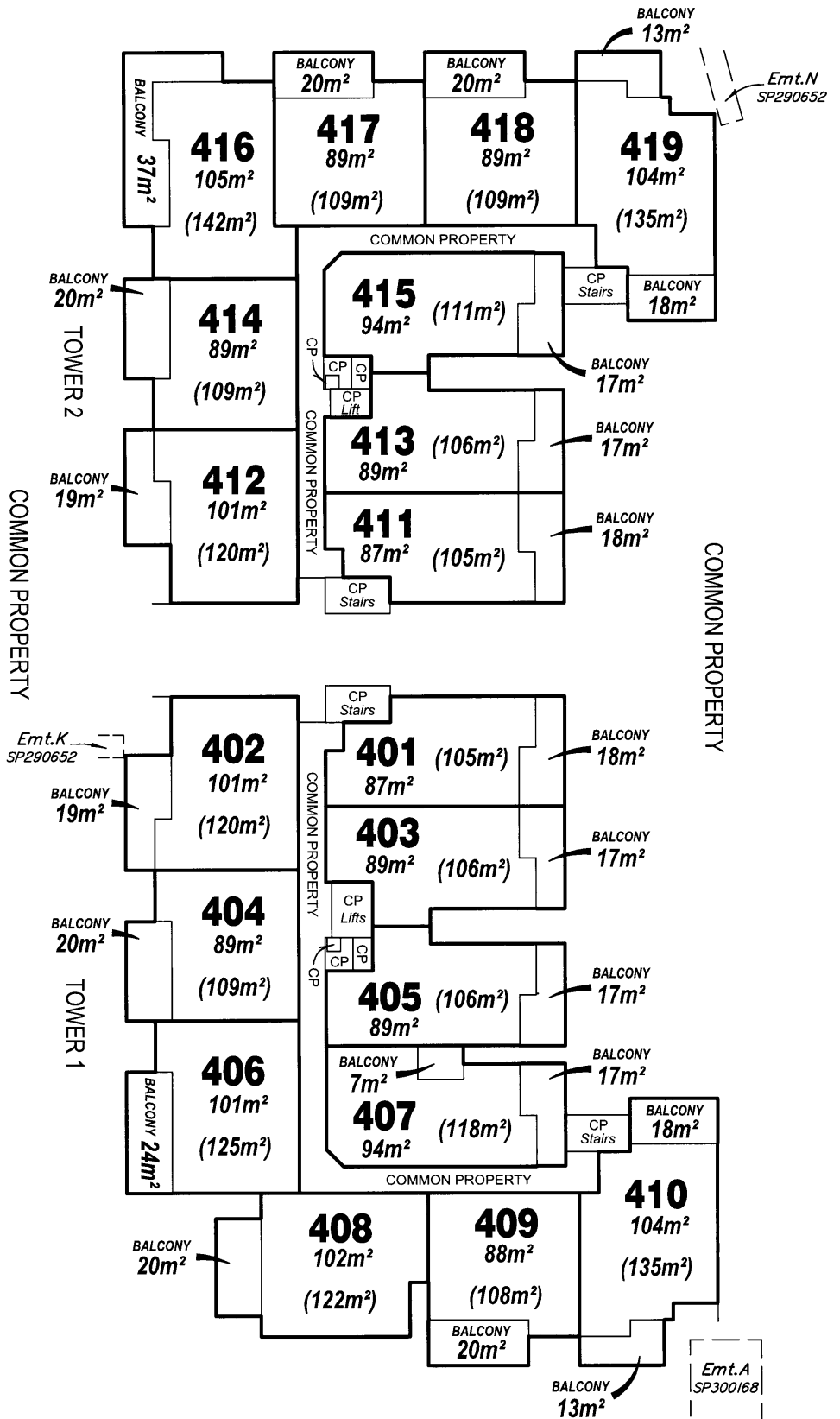
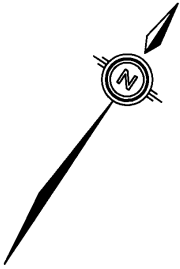

Scale 1:300 - Lengths are in Metres.

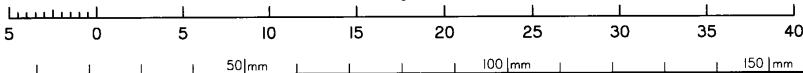

State copyright reserved.

Insert Plan Number **SP300172**

LEVEL G

Scale 1:300

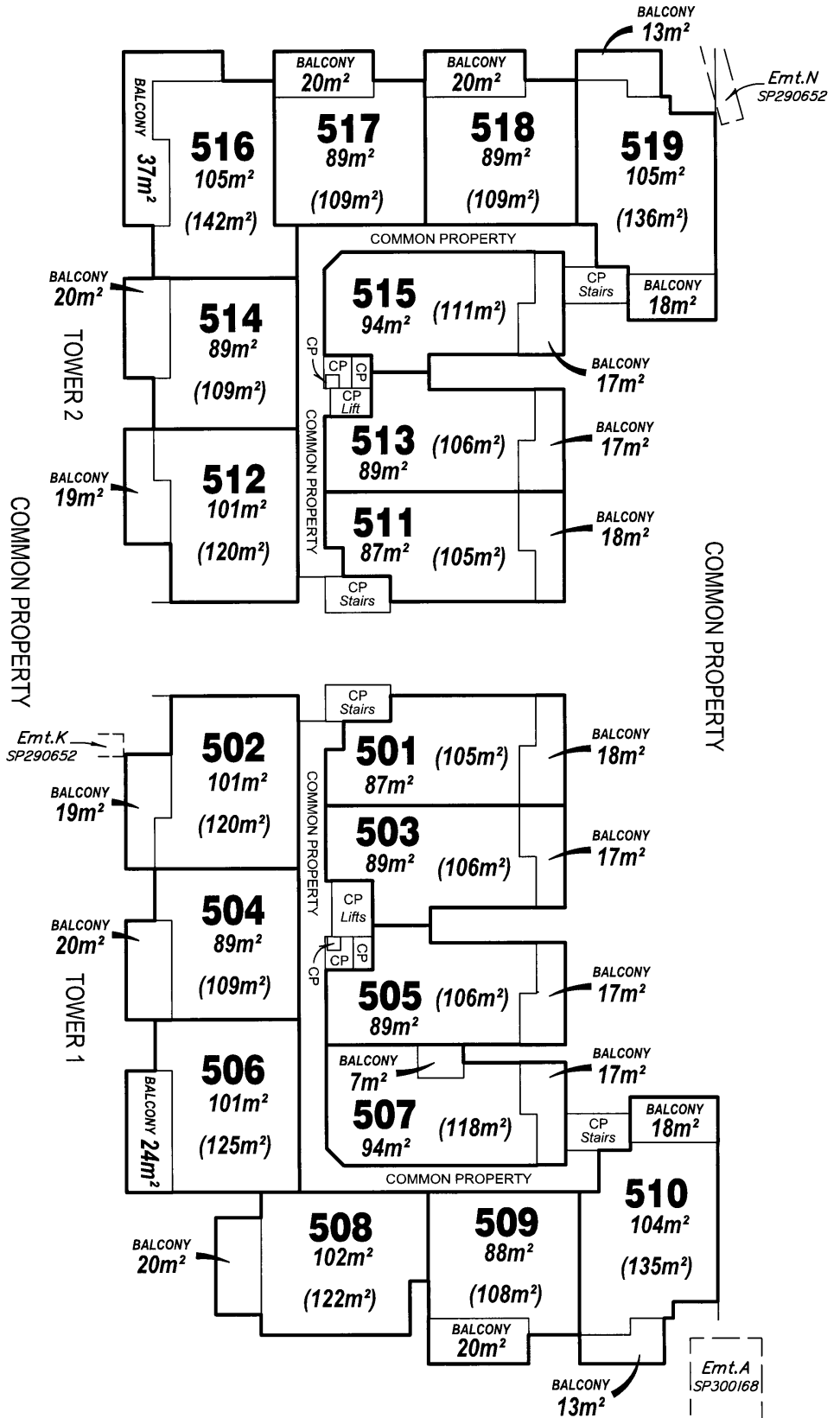
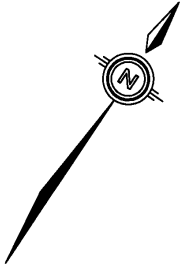

Scale 1:300 - Lengths are in Metres.

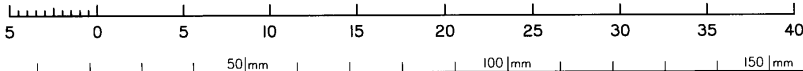

State copyright reserved.

Insert Plan Number **SP300172**

LEVEL H

Scale 1:300

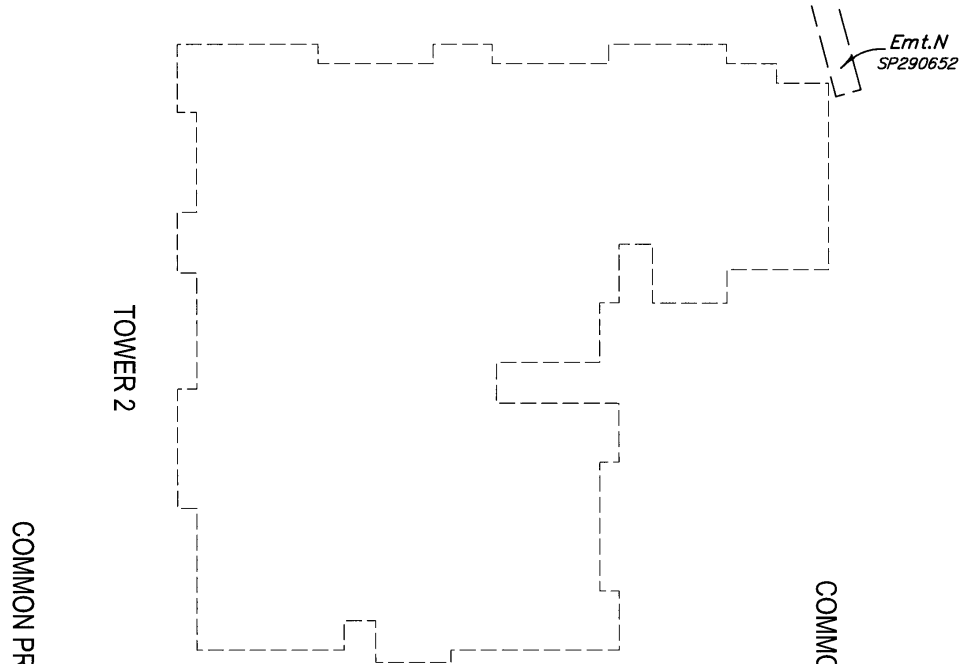
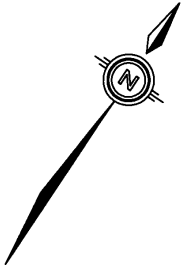

COMMON PROPERTY

COMMON PROPERTY

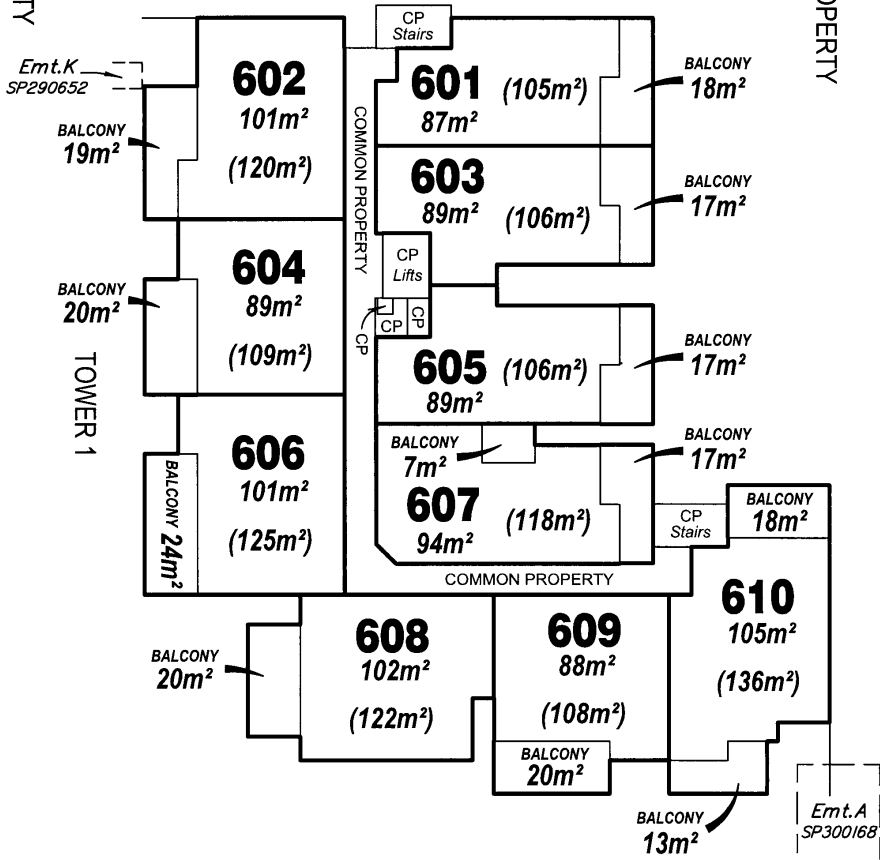

--- DENOTES LEVEL BELOW

Scale 1:300 - Lengths are in Metres.

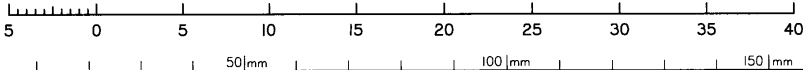

State copyright reserved.

Insert Plan Number

SP300172